



# Therma-Stor II-1

TS-209B  
Revised 6/13

## Heat Recovery Water Heater Specification Information



Therma-Stor plate design, with rapid, free-flowing paths for refrigerant gas, promotes excellent waste heat transfer throughout the tank.

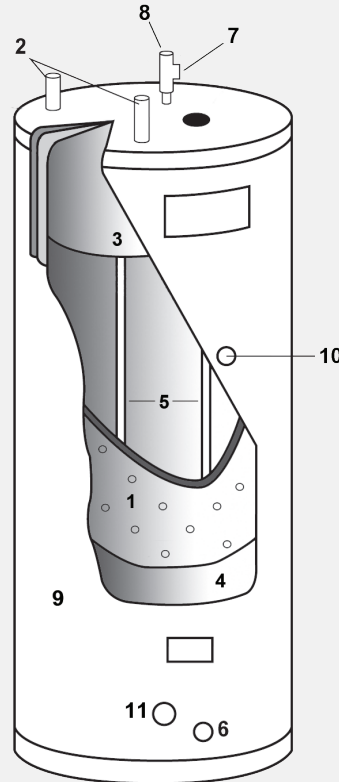
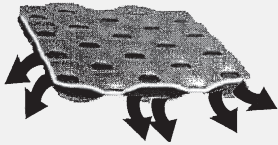

### Construction Specifications

1. Single-circuit refrigerant heat exchange plate designed for maximum heat transfer with minimum pressure drop.
2. 1-5/8" O.D. refrigerant inlet and outlet (1 1/2" steel MPT on the II-1-A).
3. Industrial glass lined 114-gallon hot water storage tank.
4. 2" foam-in-place urethane insulation (R-16).
5. Dual anode protection against corrosion for extended tank life.
6. 1-1/4" male NPT water inlet.
7. 1-1/4" male NPT water outlet.
8. 150 psi and 210°F pressure/temperature relief valve.
9. Attractive enameled galvanized external wrapper.
10. Mid-tank 3/4" Male NPT connection for recirculating loop return or for aquastat (mid-port).
11. Stub out for equalization tube (recommended for use when two or more Therma-Stors are piped in parallel; see diagram D).

### Overview

The Therma-Stor II-1 Heat Recovery Water Heater features a single-circuit heat exchanger encompassing a 114-gallon water tank. The II-1 is compatible with refrigeration loads of up to 60 tons depending on refrigerant type and evaporator temperatures. The Therma-Stor II-1-A is designed for ammonia refrigerant (R717) and is compatible with 100+ tons (refer to chart on the back). For larger refrigeration capacities and/or water use, multiple II-1 units can be piped together. Banks of two, three and four II-1's are common in facilities with higher hot water demand.

### Operation

The Therma-Stor II-1 heats water by transferring refrigerant superheat to water. Hot gas from the compressor is piped through the II-1 en route to the condenser. The II-1 is compatible with any typical refrigeration system within sizing guidelines (using capillary tube systems with the Therma-Stor is normally not recommended). Plumbing recirculating loop return water to the mid-port allows recirc line losses to be heated with reclaimed heat without affecting overall heating efficiency. Hot water production depends on the evaporator load (capacity), run time of the compressor and water usage (see the Therma-Stor Return On Investment Calculation Form available at [www.HeatWaterForFree.com](http://www.HeatWaterForFree.com) for more information).

### Typical Applications

The Therma-Stor II-1 is ideally suited for facilities with high capacity refrigeration systems and substantial hot water demand. The II-1 can be used as the only water heating system or as a pre-heater that feeds a conventional water heater. Common installations include:

- Grocery stores
- Supermarkets
- Processing facilities
- Ice rinks

### Unit Specifications

- Tank Dimensions  
Diameter: 29 1/4", Height: 62 1/4"
- Unit Dimensions (with fittings)  
Diameter: 31 1/2", Height: 67", Weight: 427 lbs
- 120 gallon nominal water capacity
- Rated for 450 psi refrigerant operating pressure
- Max heat exchange rating 80,000 BTU/HR
- 150 psi maximum operating water pressure
- R-16 insulation
- High refrigerant capacity
- Double wall vented protection between refrigerant and water
- Triple leak checked, shipped with N<sub>2</sub> holding charge

Part No. 4020166 – II-1

Also available:

Part No. 4021992 – II-1-A with Ammonia connections (R-717)

Specifications subject to change without notice.

### Certifications

- UL/cUL® (SA5939)
- ASHRAE 90

## Sizing Guidelines

The Therma-Stor II-1 can accommodate refrigeration loads of up to 60 tons (100+ tons for R717) depending on refrigerant and evaporator temperatures. Units can be piped together in parallel to accommodate larger loads (see diagrams below). If multiple tanks can not be used, larger loads can be accommodated by incorporating a bypass valve (see Diagram E below).

Therma-Stor units are not intended as a substitute for air or water cooled condensers. These capacity ratings are based on approximately 15 lb. pressure drop at maximum capacity.

II-1		
Max. Recommended Capacity (in tons) for Typical Refrigeration Systems		
Refrigerant	Low Temperatures	Medium Temperatures
R-22	60	64
R-134A	47	53
R-404A, R-502, R-507	42	51
R-717	100+	100+

## Water Temperature Control

Incorporating provisions in the refrigerant piping to bypass hot gas around the Therma-Stor directly to the condenser is recommended for large capacity systems. This prevents water from overheating during periods of sustained refrigeration operation with no/low water demand. A typical arrangement incorporates a three-way valve operated by an aquastat that senses water temperature. An alternate arrangement is a water bleed valve that would bleed hot water out of the tank. An aquastat can be mounted on the mid-port if there is no recirculation loop or connected to the water outlet piping to sense water temperature. Refer to diagram A below.

## Supermarket Applications

The entire refrigerant load (up to 64 tons) of the larger rack systems can be run through a single Therma-Stor II-1 Heat Recovery System.

The Therma-Stor II-1 is often plumbed in series with a conventional water heater. See diagram B. Consider using the Therma-Stor III-1 in lieu of the conventional water heater. See the III-1 spec sheet for more information.

In applications with "batch" cleaning, adding a Therma-Stor TS-120 storage tank is recommended. The TS-120 can be installed to accommodate thermal-syphoning (circulating without a pump). See diagram C, refer to TS120 spec sheet for more information.

If the Therma-Stor System is installed with a circulating loop, pump the water as slowly as possible and return to the 3/4" NPT mid-port. Do not circulate directly between the water heater and the Therma-Stor unit unless the heater has been deactivated so that it acts as storage only.

Therma-Stor units can be installed in parallel to accommodate larger loads. Connecting the equalization tubes assures pressure equalization so that refrigerant flows evenly through each tank at all times. See diagram D.

