

# HI-E Dry 100

## Installation, Operation and Maintenance Instructions

– Read and Save These Instructions –

*This manual is provided to acquaint you with the humidity control device so that installation, operation and maintenance can proceed successfully. Ultimate satisfaction depends on the quality of installation and a thorough understanding of this equipment. The humidity control device is built around tested engineering principles and has passed a thorough inspection for quality of workmanship and function.*

### HI-E Dry 100:

- Controlled by a dehumidistat with settings from 20 to 80 percent relative humidity and a positive “on” and “off” setting.
- Contains a blower switch that permits continuous blower operation independent of dehumidification.
- Portable and provided with four casters.
- Contains an internal condensate pump capable of lifting condensate 17 feet and 20 feet of condensate hose.
- Wiring is through a factory installed six foot power cord; 115 volt with ground.
- Environmentally friendly R410A refrigerant.



#### Water Removal Rates (Pints/Day)

172 pints	90° F, 90%
129 pints	80° F, 80%
<b>110 pints</b>	<b>80° F, 60% (AHAM)</b>
113 pints	70° F, 80%
83 pints	70° F, 60%
94 pints	60° F, 80%
64 pints	60° F, 60%
67 pints	50° F, 80%
25 pints	50° F, 60%



4201 Lien Rd.  
Madison, WI 53704  
www.QuestProtect.com

Toll-Free 1-800-533-7533  
sales@QuestProtect.com

Table of Contents

- 1. Specifications .....4
- 2. Installation .....4
  - 2.1 Location.....4
    - 2.1A In humid area, no ducting.....5
    - 2.1B In humid area, duct inlet and/or outlet .....5
    - 2.1C In remote area, duct inlet & outlet .....5
    - 2.1D In remote area, duct outlet only.....5
    - 2.1E In remote area, duct inlet only.....5
  - 2.2 Electrical Requirements.....5
  - 2.3 Condensate Removal ..... 6
  - 2.4 Ducting..... 6
    - 2.4A Optional Ducting ..... 6
    - 2.4B Ducting for Dehumidification .....6
    - 2.4C Ducting for Fresh Air.....6
- 3. Operation .....6
  - 3.1 Humidity Control Adjustment .....6
  - 3.2 Fan Switch ..... 7
  - 3.3 Defrost Control Adjustment.....7
- 4. Maintenance .....7
  - 4.1 Air Filter .....7
- 5. Service .....7
  - 5.1 Warranty. ....7
  - 5.2 Technical description .....7
  - 5.3 Troubleshooting .....8
  - 5.4 Refrigerant Charging .....9
  - 5.5 Blower Replacement..... 9
  - 5.6 Compressor/Capacitor Replacement.....10
    - 5.6A Checking Compressor Motor Circuits.....10
    - 5.6B Replacing a Burned Out Compressor .....10
    - 5.6C Replacing a Compressor- .....11
      - Non-Burn Out
  - 5.7 Relay.....11
  - 5.8 Humidity Control .....12
  - 5.9 Defrost Thermostat .....12
  - 5.10 Condensate Pump .....12
- 6. Wiring Diagram .....13
- 7. Service Parts List.....14
- 8. Filter Installation Instructions.....15
  - Warranty .....16

Serial No. \_\_\_\_\_

Purchase Date \_\_\_\_\_

Dealer's Name \_\_\_\_\_



## Safety Precautions

Read the installation, operation and maintenance instructions carefully **before** installing and using this unit. Proper adherence to these instructions is essential to obtain maximum benefit from your HI-E Dry 100 humidity control device.

### READ AND SAVE THESE INSTRUCTIONS

- It is designed to be installed **INDOORS ONLY**.
- **DO NOT** use the HI-E Dry 100 as a bench or table.
- Avoid discharging the air directly at people.



**1. Specifications**

Part Number	4029730
Power	110-120 VAC 6.4 amps
Kilowatts	0.70 (80° 60%)
Blower	275 CFM
Capacity (24 hrs.)	110 pints (80°, 60%)
Temp. Range	33°F–110°F
Warranty	5 Year Limited

Dimensions

	Unit	Shipping
Width	20"	25"
Height	36"	41"
Depth	17"	24"
Weight	110 Lb	125 Lb

Minimum Performance at Set Conditions

Intake Air	70° 60%	80° 60%
Water removal/day	86 Lbs	114 Lbs
Pints/KWH	6.0	6.3

**2 Installation**

**2.1 Location**

The HI-E Dry can be installed in a variety of locations to meet the owner’s needs as listed below. In all cases keep the following cautions in mind:

- It is designed to be installed *INDOORS ONLY*.
- If used near a pool or spa, be certain there is *NO* chance the unit could roll into the water or be splashed and that it is plugged into a *GROUND FAULT INTERRUPTER*.
- *DO NOT* use the HI-E Dry as a bench or table.
- Avoid discharging the air directly at people, especially in pool areas.



**2.1A In Humid Area, No Ducting**

The simplest installation is to place the HI-E Dry 100 in the humid area with no ducting. The air inlet on top & outlet on the side must be at least 1' from walls and other obstructions to air flow.

**2.1B In Humid Area, Duct inlet and/or Outlet**

If the humid area is very large or has high ceilings, dehumidification can be improved by adding an inlet and/or outlet duct to circulate and destratify stagnant areas. For a large area, add inlet or outlet ducting to create flow across the area's greatest length.

For areas with ceilings higher than 12', use an inlet duct to draw warm, moist air from near the ceiling. See section 2.4 for attaching duct collars & ducting.

**2.1C In Remote Area, Duct Inlet & Outlet**

It is often desirable, especially in finished areas, to install the HI-E Dry 100 in an adjacent equipment room or unfinished area. Air is transferred between the humid room and the unit via ducting.

The factory mounted humidity control on the HI-E Dry 100 cabinet may not sense the humidity in the humid room accurately enough with this installation method. If so, an additional humidity control can be mounted in the humid room and wired to the HI-E Dry 100. Local electrical codes must be followed when wiring the control.

**2.1D In Remote Area, Duct Outlet Only**

A simpler remote installation method than the one above uses ducting only between the HI-E Dry 100 discharge and the humid room; the HI-E Dry 100 inlet draws air from the room in which it's located. This works well if there is an adequate air flow path between the two rooms; e.g., high door undercut, louvered door or wall grill. This eliminates the need to remote mount the humidity control. There are several potential disadvantages to using this method. First, humid air is drawn into the room where the HI-E Dry 100 is located. Second, to accurately sense humidity, the blower in the HI-E Dry 100 may need to run continuously to draw air from the humid room into the HI-E Dry 100 room. Third, a slight negative pressure is created in the room with the HI-E Dry 100 which could back draft open combustion devices located there. If such devices are present, call the factory for specific instructions before using this installation method or consider the option below.

**2.1E In Remote Area, Duct Inlet Only**

When the HI-E Dry 100 is located in a room separate from the main area to be dehumidified, it may be desirable to dehumidify and/or slightly pressurize that room. Pressurization assures that open combustion devices do not back draft as would be the case if the room was sufficiently de-pressurized. This can be accomplished by installing a duct from the humid room to the HI-E Dry 100 inlet and by allowing the HI-E Dry 100 to discharge the dehumidified air into the room in which it's located. An adequate air flow path must exist between the two rooms for this method to work well. An additional humidity control may need to be mounted in the humid area and wired to the HI-E Dry 100 to accurately maintain the desired humidity. Local electrical codes must be followed when wiring the control.

**2.2 Electrical Requirements**

The HI-E Dry plugs into a common grounded outlet on a 15 Amp circuit. It draws between 6 and 7 Amps under normal operating conditions. If used in a wet area (pool, spa room, or basement prone to flooding), a ground fault interrupter protected circuit is required.

If an extension cord is required, it must have a minimum of 16 gauge conductors if less than 25 feet long and 14 gauge if greater than 25 feet.



## 2.3 Condensate Removal

The HI-E Dry 100 is equipped with a condensate pump to remove the water that is condensed during dehumidification. This allows the condensate to be disposed of at a distant location, or to be pumped to a level above the HI-E Dry 100. The condensate pump is mounted inside the HI-E Dry 100 as an integral part of the unit. If the condensate must be pumped more than 18 feet above the unit, a second pump must be added to relay the condensate.

## 2.4 Ducting

### 2.4A Optional Ducting

An inlet shroud with a 8" round collar and an 8" round exhaust collar are available from the factory that will allow round ducting to be attached to the inlet and/or outlet of the HI-E Dry 100.

### 2.4B Ducting for Dehumidification

Ducting the HI-E Dry 100 as mentioned in sections 2.1B-2.1E requires consideration of the following points.

**Duct Sizing:** For total duct lengths up to 25', use a minimum 8" diameter round or equivalent rectangular. For longer lengths, use a minimum 10" diameter or equivalent. Grills or diffusers on the duct ends must not excessively restrict air flow.

**Isolated Areas:** Effective dehumidification may require that ducting be branched to isolated, stagnant areas. Use 6" diameter branch ducting to each of two or three areas; use 4" to each of four or more areas.

### 2.4C Ducting for Fresh Air

Fresh air can be brought into the structure continuously by connecting a duct from outside to the HI-E Dry 100 inlet and by turning on the fan switch. Advantages of this form of ventilation include:

1. Outside air is filtered before entering the building.
2. Outside air will be dehumidified before entering if the HI-E Dry 100 is running.
3. Drawing air from outside and blowing inside aids in pressurizing the structure. This helps prevent unfiltered and undehumidified air from entering elsewhere. It also reduces the potential for carcinogenic radon gas to enter.
4. The need for an alternate ventilation device may be eliminated.

## 3. Operation

### 3.1 Humidity Control Adjustment

The humidity control device will run continuously until the relative humidity (RH) is reduced to the humidity control dial setting. Setting the humidity control to lower RH levels will NOT increase the unit's dehumidification rate, it will simply run longer to reduce the area's RH to the setting. The HI-E Dry 100 unit (and refrigerant based humidity control devices in general) will reduce a warm space's RH to a lower level than that of a cool space. It is therefore pointless to set the humidity control to excessively low levels in cool rooms. Doing so will result in long periods of ineffective humidity control device run time.

A quality humidity meter is recommended to accurately monitor humidity levels. For a quote on a quality humidity meter, call the factory.



### 3.2 Fan Switch

Turning the fan switch ON will cause the unit's internal blower to run continuously, whether the unit is dehumidifying or not. This function is desirable if the unit is used for air circulation or fresh air ventilation.

### 3.3 Defrost Control Adjustment

When the HI-E *Dry* 100 is used in a cool area, frost will form on the cooling coil as it dehumidifies. When enough frost forms, the defrost thermostat will initiate the timed defrost cycle. The cycle periodically turns off the compressor while allowing the blower to run. The air that the blower draws through the cooling coil melts the frost.

The defrost cycle is automatic and designed for optimum performance above 50°F.

## 4. Maintenance

### 4.1 Air Filter

The HI-E *Dry* 100 is equipped with a 2" thick, 35% efficient pleated fabric air filter that must be checked regularly. Operating the unit with dirty filters will reduce the humidity control device's capacity and efficiency and may cause the compressor to cycle off and on unnecessarily on the defrost control.

The filter can generally be vacuumed clean several times before needing replacement. Replacement filters can be ordered from the factory or purchased locally if available. **DO NOT** operate the unit without the filter or with a less effective filter as the heat exchange coils inside the unit could become clogged and require disassembly to clean.

## 5. Service

**CAUTION: Servicing the HI-E *Dry* 100 with its high-pressure refrigerant system and high voltage circuitry presents a health hazard which could result in death, serious bodily injury, and/or property damage. Only qualified service people should service this unit.**

### 5.1 Warranty

A warranty certificate has been enclosed with this unit. Read it before any repair is initiated. If a warranty repair is required, call the factory first at 1-800-533-7533 for warranty claim authorization and technical assistance.

### 5.2 Technical Description

Refer to Figure 3. The HI-E *Dry* 100 uses a refrigeration system similar to an air conditioner's to remove heat and moisture from incoming air, and add heat to the air that is discharged.

Hot, high-pressure refrigerant gas is routed from the compressor to the condenser coil. The refrigerant is cooled and condensed by giving up its heat to the air that is about to be discharged from the unit. The refrigerant liquid then passes through two capillary tubes, which cause the refrigerant pressure and temperature to drop. It next enters the evaporator coil where it absorbs heat from the incoming air and evaporates.

The evaporator operates in a flooded condition, which means that it should always be full of liquid refrigerant during normal operation. A flooded evaporator should maintain constant pressure and temperature across the entire coil, from inlet to outlet.



The mixture of gas and liquid refrigerant enter the accumulator after leaving the evaporator coil. The accumulator prevents any liquid refrigerant from reaching the compressor. The compressor evacuates the cool refrigerant gas from the accumulator and compresses it to a high pressure and temperature to repeat the process.

**5.3 Troubleshooting**

**No dehumidification, neither blower nor compressor run with fan switch OFF.**

1. Unit unplugged or no power to outlet.
2. Humidity control set too high or defective (Sec. 3.1 & 5.9)
3. Loose connection in internal wiring.

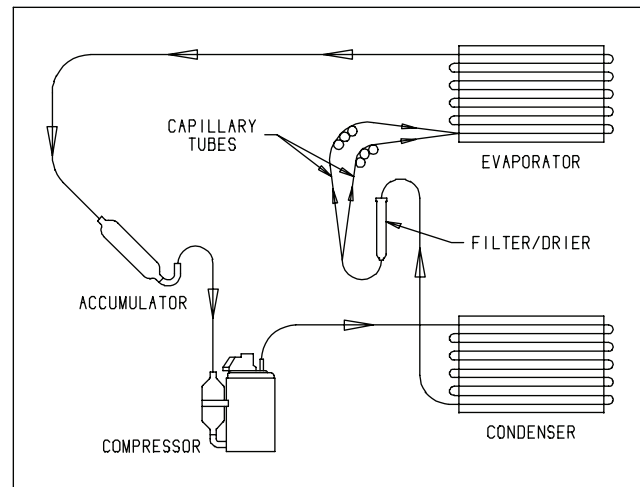

Figure 3: Refrigeration system of HI-E Dry 100

**Some dehumidification, blower runs continuously but compressor only runs sporadically with fan switch OFF.**

1. Unit is in defrost cycle (Sec. 3.3 & 5.10).
2. Defrost thermostat defective or loose (Sec. 3.3 & 5.10).
3. Loose connection in compressor circuit (see Fig. 4).
4. Defective compressor overload (Sec. 5.6A).
5. Defective compressor (Sec. 5.6).
6. Defective relay (Sec. 5.8).
7. Defective defrost timer (Sec. 5.10).

**No dehumidification. Blower runs but compressor does not with fan switch OFF.**

1. Bad connection in compressor circuit (Fig. 4).
2. Defective compressor capacitor (Sec. 5.6A).
3. Defective compressor overload (Sec. 5.6A).
4. Defective compressor (Sec. 5.6).
5. Defective relay (Sec. 5.8).
6. Defective defrost timer (Sec. 5.10).
7. Bad connection in pump circuit (Fig. 4).
8. Pump float switch or safety switch open (Sec. 5.11).
9. Pump motor defective (Sec. 5.11).

**Blower does not run. Compressor runs briefly but cycles on & off.**

1. Loose connection in blower circuit (Fig. 4).
2. Obstruction prevents impeller rotation.
3. Defective blower (Sec. 5.5).





**Unit removes some water but not as much as expected.**

1. Air temperature and/or humidity have dropped.
2. Humidity meter and/or thermometer used are out of calibration.
3. Unit has entered defrost cycle (Sec. 3.3 & 5.10).
4. Air filter dirty (Sec. 4.1).
5. Defrost timer incorrectly set for conditions (Sec. 3.3 & 5.10).
6. Defective defrost thermostat (Sec. 5.10).
7. Low refrigerant charge (Sec. 5.4).
8. Air leak such as loose cover.
9. Defective compressor (Sec. 5.6).
10. Restrictive ducting (Sec. 2.4).

**Pump does not pump water.**

1. Hose kinked or plugged.
2. Pump check valve plugged (Sec. 5.11).
3. Bad connection in pump circuit (Fig. 4).
4. Hose disconnected internally.

**Evaporator coil frosted continuously, low dehumidifying capacity.**

1. Defrost thermostat loose or defective (Sec. 3.3 & 5.10).
2. Low refrigerant charge (Sec. 5.4).
3. Dirty air filters or airflow restricted. (Sec. 4.1).
4. Defrost timer set incorrectly (Sec. 3.3).

**5.4 Refrigerant Charging**

If the refrigerant charge is lost due to service or a leak, a new charge must be accurately weighed in. If any of the old charge is left in the system, it must be removed before weighing in the new charge. Refer to the unit nameplate for the correct charge weight and refrigerant type. Add the refrigerant through the low side service port (See Fig. 5).

**5.5 Blower Replacement**

The centrifugal blower has a PSC motor and internal thermal overload protection. If defective, the complete assembly must be replaced.

1. Unplug the power cord.
2. If an outlet duct is connected to the unit, remove it.
3. Remove the cabinet side.
4. Remove the 4 screws holding the electrical box located next to the blower.
5. Disconnect the blower leads. Black from the blower switch, and white the run capacitor.
6. Unbolt the blower capacitor from the blower motor (required for removal clearance).
7. Remove the nuts & bolts holding the blower outlet flange to the cabinet end and remove the blower.
8. Reassembling with the new blower is the above procedure reversed.



## 5.6 Compressor/Capacitor Replacement

This compressor is equipped with a two terminal external overload, run capacitor, but no start capacitor or relay (see Fig. 4).

**CAUTION-ELECTRICAL SHOCK HAZARD: Electrical power must be present to perform some tests; these tests should be performed by a qualified service person.**

### 5.6A Checking Compressor Motor Circuits

Perform the following tests if the blower runs but the compressor does not with the humidity control ON.

1. Turn the humidity control OFF and unplug the unit, remove the cabinet front (6 screws).
2. Plug in the unit and turn the humidity control ON. Use a voltmeter to check for 110 to 120 volts between (a) the relay terminal that the black wire from the compressor connects to and (b) the capacitor terminal with the (2) white wires, (1) red wire & (1) brown wire connected. If voltage is present, go to step 3. If no voltage, the defrost thermostat, the relay or the condensate pump safety switch are open or there is a loose connection in the compressor circuit. Test each component for continuity; see the appropriate section if a defect is suspected.
3. Turn the humidity control OFF and unplug the unit, then disconnect the red and yellow wires from compressor terminals R & S. Using an ohmmeter check continuity between the points listed below.
4. Compressor terminals C and S: No continuity indicates an open start winding; the compressor must be replaced.
5. Compressor terminals C and R: No continuity indicates an open run winding; the compressor must be replaced.
6. Compressor terminal C and overload terminal 1: No continuity indicates a defective overload lead.
7. Overload terminals 1 and 3: If there is no continuity, the overload may be tripped; wait 10 minutes and try again. If there is still no continuity, it is defective and must be replaced.
8. Compressor terminal C and compressor case: Continuity indicates a grounded motor; the compressor must be replaced.
9. Disconnect the wires from the capacitor. Set the ohmmeter to the Rx1 scale; the capacitor is shorted and must be replaced if continuity exists across its terminals. If there is no needle movement with the meter set on the Rx100000 scale, the capacitor is open and must be replaced.
10. Reconnect the wires to the compressor and capacitor; plug in and turn on the unit. If the compressor fails to start, replace the run capacitor.
11. If the unit still does not start, adding a hard-start kit will provide greater starting torque. If this does not work, the compressor has an internal mechanical defect and must be replaced.

### 5.6B Replacing a Burned Out Compressor

The refrigerant and oil mixture in a compressor is chemically very stable under normal operating conditions. However, when an electrical short occurs in the compressor motor, the resulting high temperature arc causes a portion of the refrigerant oil mixture to break down into carbonaceous sludge, a very corrosive acid, and water. These contaminants must be carefully removed otherwise even small residues will attack replacement compressor motors and cause failures.



The following procedure is effective only if the system is monitored after replacing the compressor to insure that the clean up was complete.

1. This procedure assumes that the previously listed compressor motor circuit tests revealed a shorted or open winding. If so, cautiously smell the refrigerant from the compressor service port for the acid odor of a burn out.

**WARNING: The gas could be toxic and highly acidic. If no acid odor is present, skip down to the section on changing a non-burn out compressor.**

2. Remove and properly dispose of the system charge. DO NOT vent the refrigerant or allow it to contact your eyes or skin.
3. Remove the burned out compressor. Use rubber gloves if there is any possibility of coming in contact with the oil or sludge.
4. To facilitate subsequent steps, determine the type of burn out that occurred. If the discharge line shows no evidence of sludge and the suction line is also clean or perhaps has some light carbon deposits, the burn out occurred while the compressor was not rotating. Contaminants are therefore largely confined to the compressor housing. A single installation of liquid and suction line filter/driers will probably clean up the system.

If sludge is evident in the discharge line, it will likely be found in the suction line; this indicates the compressor burned out while running. Sludge and acid have been pumped throughout the system. Several changes of the liquid and suction filter/driers will probably be necessary to cleanse the system.

5. Correct the system fault that caused the burn out. Consult the factory for advice.
6. Install the replacement compressor with a new capacitor and an oversized liquid line filter.  
In a running burn out, install an oversized suction line filter/drier between the accumulator and compressor. Thoroughly flush the accumulator with refrigerant to remove all trapped sludge and to prevent the oil hole from becoming plugged. A standing burn out does not require a suction line filter/drier.
7. Evacuate the system with a good vacuum pump and accurate vacuum gauge. Leave the pump on the system for at least an hour.
8. Operate the system for a short period of time, monitoring the suction pressure to determine that the suction filter is not becoming plugged. Replace the suction filter/drier if pressure drop occurs. If a severe running burn out has occurred, several filter/driers may have to be replaced to remove all of the acid and moisture.

**NOTE: NEVER use the compressor to evacuate the system or any part of it.**

### 5.6C Replacing a Compressor- Non-Burn Out

Remove the refrigerant from the system. Replace the compressor and liquid line filter/drier. Charge the system to 50 PSIG and check for leaks. Remove the charge and weigh in the refrigerant quantity listed on the nameplate. Operate the system to verify performance.

### 5.7 Relay

The contacts of the single pole, single throw relay complete the power circuit to the compressor. The contacts are closed when power is provided to the relay coil via the control circuit. The control circuit includes the humidity control, defrost thermostat and timer.



### 5.8 Humidity Control

The humidity control is an adjustable switch that closes when the relative humidity of the air in which it is located rises to the dial set point. It opens when the RH drops 4 to 6% below the set point.

### 5.9 Defrost Thermostat & Timer

The defrost thermostat is attached to the refrigerant suction tube between the accumulator and compressor. If the low side refrigerant temperature drops due to excessive frost formation on the evaporator coil, the thermostat opens. The compressor is then cycled off and on by the defrost timer. The blower will continue to run, causing air to flow through the evaporator coil and melt the ice when the compressor is off. When the air temperature and/or humidity increase, the evaporator temperature will rise and the thermostat will close to end the defrost cycle.

### 5.10 Condensate Pump

Condensate is automatically pumped when the water level in the pump's reservoir rises to close the float switch.

If the pump is unable to empty its reservoir due to a pump failure or blocked condensate hose, a pump safety float switch is triggered before the reservoir overflows. The switch turns off the compressor via its relay.

To replace the condensate pump:

1. Unplug the unit & remove the front cover.
2. Disconnect the 2 hoses from the pump.
3. Cut the pump lead wires near the old pump.
4. Remove the 2 nuts from the unit side that hold the pump to the side.
5. Attach the new pump with 2 nuts.
6. Connect the new pump wiring.
7. Connect the hoses to the new pump. Carefully route the hoses so they do not contact the copper refrigerant lines or the compressor shell.



6. Wiring Diagram

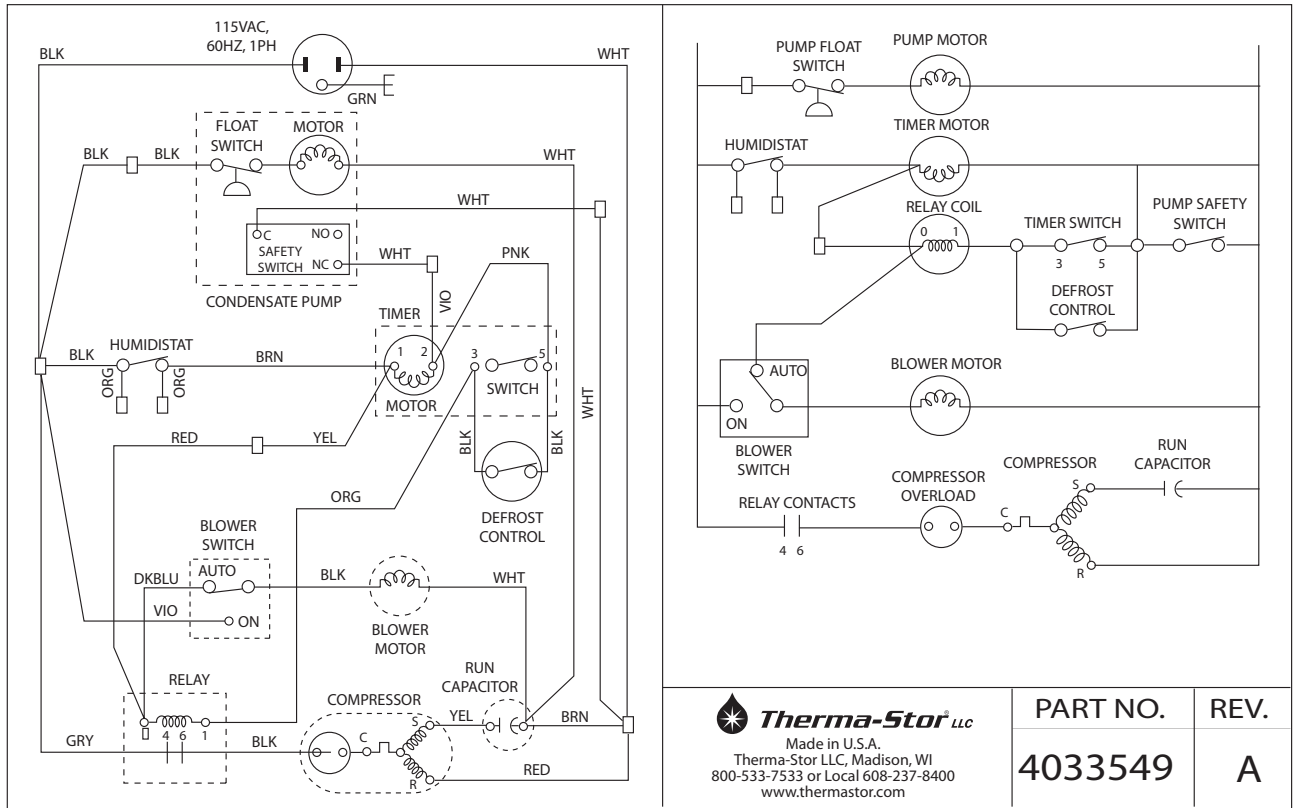
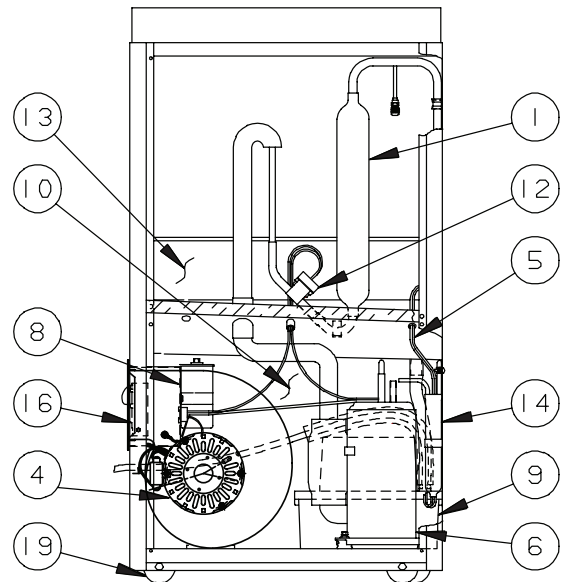
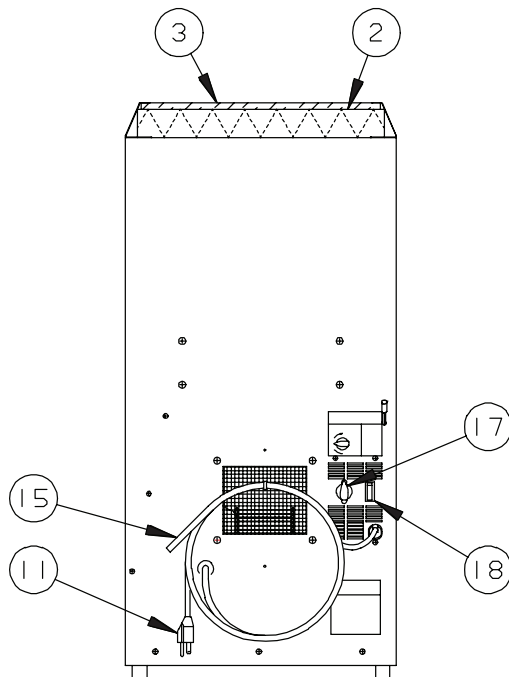

Figure 4: Electrical Schematic of HI-E Dry 100

7. Service Parts: HI-E Dry 100 Humidity control device

ITEM	PART NO.	QTY.	DESCRIPTION
1	4022254	1	Accumulator
2	4021475	1	Air Filter, Pleated, 2" x 16" x 20"
3	4021468	1	Air Filter, Foam Element
4	4026930	1	Blower, w/Capacitor, 115V
5	4028233	3	Capillary Tubes
6	4032371	1	Compressor Kit (includes Overload), Panasonic (2R12S3R126A-6A)
7	4029169	1	Compressor Overload (not shown)
8	4033032-05	1	Compressor Run Capacitor, 45 MFD, 370V
9	4034097	1	Condensate Pump
10	4028226	1	Condenser Coil
11	4023495	1	Cord & Wire Harness
12	4025741	1	Defrost Thermostat
	4021648	1	Defrost Control Mounting Clip
13	4033925-02	1	Evaporator Coil
14	4029510	1	Filter/Drier
15	4024916	1	Hose, Drain, .25" IDx33FT
16	4027172	1	Humidity Controller
17	4021495	1	Knob, Humidity Controller
18	4025560	1	Switch, SPDT, for Fan
19	4021471	4	Wheel, 2", Plastic
20	4033549	1	Wiring Diagram (on Cover) (not shown)
21	4021453	1	Optional Ducting Kit (for Inlet & Outlet) (not shown)
22	4020623	1	Optional Outlet Collar (for Ducting Outlet only) (not shown)
23	4021823	1	Defrost Timer (not shown)
24	1970010	1	Relay (not shown)



### 8. Filter Installation Instructions

To prevent damaging the foam filter, place it "grid side up" on top of the pleated filter and slide them both into the filter slot.

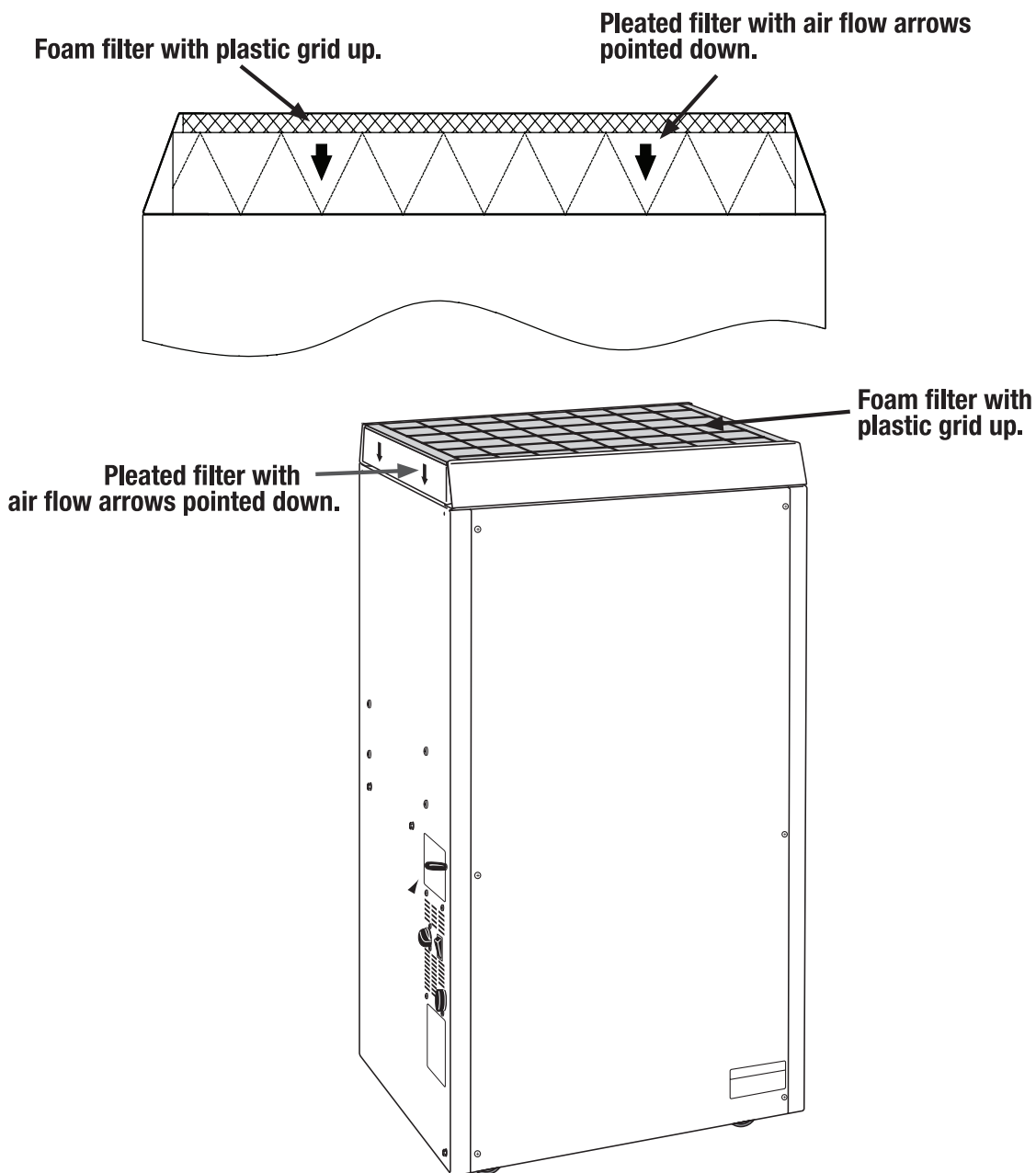

## HI-E Dry 100 Humidity Control Device Limited Warranty

**Warrantor:**

Therma-Stor LLC  
4201 Lien Rd  
Madison, WI 53704  
Telephone: 1-800-533-7533

**Who Is Covered:** This warranty extends only to the original end-user of the HI-E Dry 100 humidity control device, and may not be assigned or transferred.

**Year One:** Therma-Stor warrants that, for one (1) year the HI-E Dry 100 humidity control device will operate free from any defects in materials and workmanship, or Therma-Stor will, at its option, repair or replace the defective part(s), free of any charge.

**Year(s) Two Through Five:** Therma-Stor further warrants that for a period of five (5) years, the condenser, evaporator, and compressor of the HI-E Dry 100 humidity control device will operate free of any defects in material or workmanship, or Therma-Stor, at its option, will repair or replace the defective part(s), provided that all labor and transportation charges for the part(s) shall be borne by the end-user.

**End-User Responsibilities:** Warranty service must be performed by a Servicer authorized by Therma-Stor. If the end-user is unable to locate or obtain warranty service from an authorized Servicer, he should call Therma-Stor at the above number and ask for the Therma-Stor Service Department, which will then arrange for covered warranty service. Warranty service will be performed during normal working hours.

The end-user must present proof of purchase (lease) upon request, by use of the warranty card or other reasonable and reliable means. The end-user is responsible for normal care. This warranty does not cover any defect, malfunction, etc. resulting from misuse, abuse, lack of normal care, corrosion, freezing, tampering, modification, unauthorized or improper repair or installation, accident, acts of nature or any other cause beyond Therma-Stor's reasonable control.

**Limitation and Exclusions:** If any HI-E Dry 100 Humidity control device part is repaired or replaced, the new part shall be warranted for only the remainder of the original warranty period applicable thereto (but all warranty periods will be extended by the period of time, if any, that the HI-E Dry 100 Humidity control device is out of service while awaiting covered warranty service).

UPON THE EXPIRATION OF THE WRITTEN WARRANTY APPLICABLE TO THE HI-E Dry 100 Humidity control device OR ANY PART THEREOF, ALL OTHER WARRANTIES IMPLIED BY LAW, INCLUDING MERCHANTABILITY AND FITNESS FOR A PARTICULAR PURPOSE, SHALL ALSO EXPIRE. ALL WARRANTIES MADE BY THERMA-STOR ARE SET FORTH HEREIN, AND NO CLAIM MAY BE MADE AGAINST THERMA-STOR BASED ON ANY ORAL WARRANTY. IN NO EVENT SHALL THERMA-STOR, IN CONNECTION WITH THE SALE, INSTALLATION, USE, REPAIR OR REPLACEMENT OF ANY HI-E Dry 100 Humidity control device OR PART THEREOF BE LIABLE UNDER ANY LEGAL THEORY FOR ANY SPECIAL, INDIRECT OR CONSEQUENTIAL DAMAGES INCLUDING WITHOUT LIMITATION WATER DAMAGE (THE END-USER SHOULD TAKE PRECAUTIONS AGAINST SAME), LOST PROFITS, DELAY, OR LOSS OF USE OR DAMAGE TO ANY REAL OR PERSONAL PROPERTY.

Some states do not allow limitations on how long an implied warranty lasts, and some do not allow the exclusion or limitation of incidental or consequential damages, so one or both of these limitation may not apply to you.

**Legal Rights:** This warranty gives you specific legal rights, and you may also have other rights which vary from state to state.

