

INSTALLER'S & OWNER'S MANUAL

HVAC INSTALLER: PLEASE LEAVE MANUAL FOR HOMEOWNER



Free-standing Moisture Control for Large Areas

P/N 4025081 • Serial No. _____ Install Date: _____

Sold by:



Therma-Stor[®] LLC

Driven by performance. Powered by design.[™]

P.O. Box 8680 Madison, WI 53708 • TOLL-FREE 1-800-533-7533 • www.thermastor.com • sales@thermastor.com

© 2008 Therma-Stor LLC • Manual P/N TS- 288 1/08

TABLE OF CONTENTS

Table of Contents

1. Registration	2
2. Specifications	2
3. Installation	2
3.1 Location	2
3.1A In Humid Area, No Ducting	2
3.1B In Humid Area, Duct Inlet and/or Outlet	2
3.1C In Remote Area, Duct Inlet & Outlet	3
3.1D In Remote Area, Duct Outlet Only	3
3.1E In Remote Area, Duct Inlet Only	3
3.2 Electrical Requirements	4
3.3 Condensate (Water) Removal	4
3.4 Drainage and Trap	4
4. Ducting	4
4.1 Optional Ducting Kit	4
4.2 Ducting for Dehumidification	4
5. Operation	4
5.1 Humidity Control Adjustment	4
5.2 Blower (Fan) Switch	5
6. Maintenance	5
6.1 Air Filter	5
6.2 Blower Oiling	5
7. Service	5
7.1 Technical description	5
7.2 Troubleshooting	6
7.3 Defrost Thermostat	6
8. Service Parts List	6
9. Accessory/Replacement Parts List	6
10. Wiring Diagram	7
Optional Remote Humidity Control	8
Condensate Pump Installation Instructions	9
Warranty	10

Read the installation, operation and maintenance instructions carefully before installing and using this unit. Proper adherence to these instructions is essential to obtain maximum benefit from your Santa Fe HC dehumidifier.

Read and Save These Instructions

⚠ WARNING! — This symbol means important instructions. Failure to heed them can result in serious injury or death.

⚠ CAUTION! — This symbol means important instructions. Failure to heed them can result in injury or material property damage.

1. Registrations

The Santa Fe HC conforms to UL STD 1995.

2. Specifications

Part Number:	4025081	
Blower:	320 CFM @ 0.0" WG	
	305 CFM @ 0.2" WG	
	285 CFM @ 0.4" WG	
Power:	1130 Watts @ 80°F and 60% RH	
Supply Voltage:	115 volt – 1 phase – 60 Hz	
Current Draw:	9.3 AMPS	
Energy Factor:	2.15 L/kWh	
Operating Temp.:	45°F Min., 95°F Max.	
Sized for:	3200 Sq. Ft. - Typical	
Minimum Performance at 80°F and 60% RH		
Water Removal:	123 Pints/Day	
Efficiency:	4.8 Pints/kWh	
Air Filter:	MERV-11	
Efficiency:	Standard 65% Efficient, ASHRAE Dust Spot Test	
Size:	16" x 20" x 2'	
Power Cord:	6', 110-120 VAC, Ground	
Drain Connection:	9/16" ID x 8' Direct Gravity Drain Hose	
Dimensions	Unit	Shipping
Width:	33"	39"
Height:	18-3/4"	28-1/2"
Depth:	20-3/4"	25"
Weight:	100 lbs	138 lbs

3. Installation

3.1 Location

The Santa Fe HC can be installed in a variety of locations to meet the owner's needs; other considerations include:

1. Providing access to a 115 VAC power outlet (7' power cord is provided).
2. Locating near a floor or other suitable drain (4' drain hose included).
3. Do not install the Santa Fe HC with the exhaust of the unit within 1' of a wall or obstruction. Do not place the unit near open water.

3.1A In Humid Area, No Ducting (fig. 1)

The simplest installation is to place the Santa Fe HC in the humid area with no ducting. To ensure optimal performance, the air inlet and the outlet of the unit must be at least 1' from walls and other obstructions to air flow.

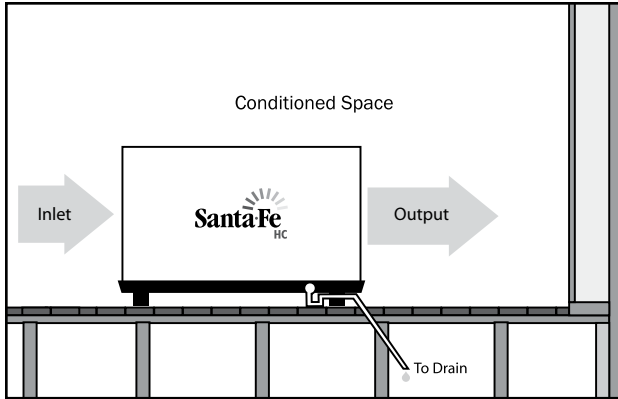

Figure 1: Installation in humid area with no ducting.

3.1B In the Humid Area, Duct Inlet and/or Outlet (fig. 2)

If the humid area is large or has high ceilings, dehumidification can be improved by adding an inlet and/or outlet duct to circulate and destratify stagnant areas. For a large area, add inlet or outlet ducting to create flow across the area's greatest length.

For areas with ceilings higher than 12', use an inlet duct to draw warm, moist air from near the ceiling. See section 5 for attaching duct collars & ducting.

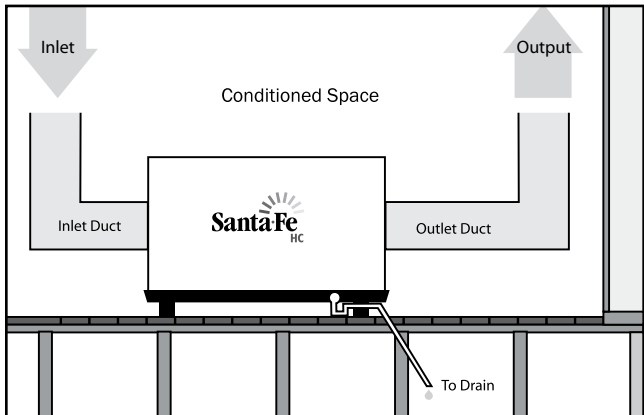

Figure 2: Installation in humid area with inlet and outlet ducting

3.1C In A Remote Area, Duct Inlet & Outlet (fig. 3)

It is often desirable, especially in recreational rooms and finished areas, to install the Santa Fe HC in an adjacent equipment room or unfinished area. Air is transferred between the humid room and the unit via ducting. The factory mounted humidity control on the Santa Fe HC cabinet may not sense the humidity in the humid room accurately enough with this installation method. If so, a remote humidity control can be mounted in the humid room and wired to the Santa Fe HC. Refer to the optional equipment table in this document. Local electrical codes must be followed when wiring the control.

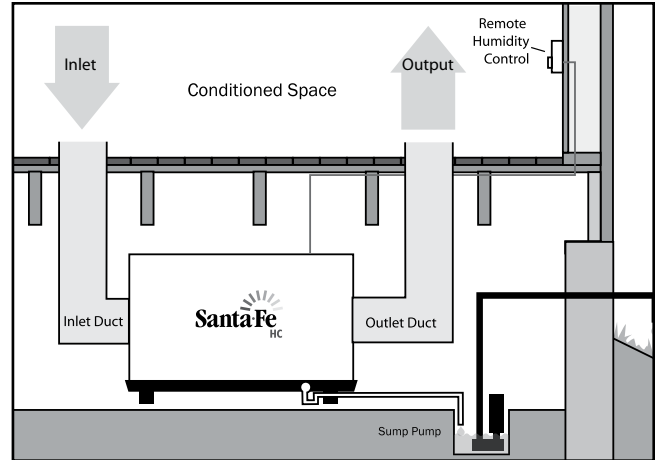

Figure 3: Installation in a remote area with ducted inlet and outlet

3.1D In A Remote Area, Duct Outlet Only (fig. 4)

A simplified remote installation method than above uses ducting between the Santa Fe HC discharge and the humid room; the Santa Fe HC inlet draws air from the room in which it's located. This works well if there is an adequate air flow path between the two rooms; e.g. high door undercut, louvered door or wall grill. This eliminates the need to remote mount the humidity control.

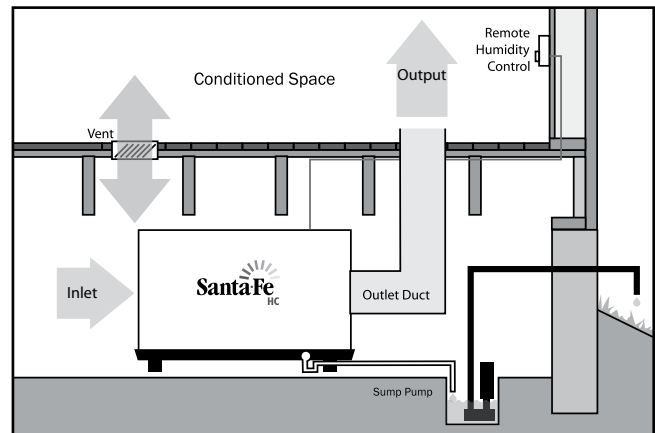

Figure 4: Installation in a remote area with ducted outlet only

⚠ WARNING! Before installing the dehumidifier in the manner described in section 3.1E (Fig. 6), call the factory for specific instruction if backdraft devices (i.e. hot water heaters) are present in the space to be dehumidified.

3.1E In A Remote Area, Duct Inlet Only (fig. 5)

When the Santa Fe HC is located in a room separate from the main area to be dehumidified, it may be desirable to dehumidify and/or slightly pressurize that room. Pressurization assures that open combustion devices do not backdraft. This can be prevented by installing a duct from the humid room to the Santa Fe HC inlet and by allowing the Santa Fe HC to discharge dehumidified air into the

room in which it's located. An adequate air flow path must exist between the two rooms for this method to work well.

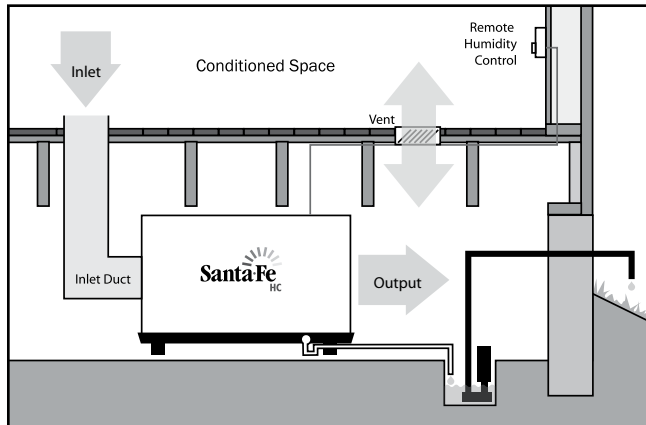

Figure 5: Installation in a remote area with ducted inlet only

A remote humidity control may need to be mounted in the humid area and wired to the Santa Fe HC to accurately maintain the desired humidity. Local electrical codes must be followed when wiring the control.

3.2 Electrical Requirements

The Santa Fe HC plugs into a common grounded outlet on a 15 Amp circuit. It draws between 12 and 13 Amps under normal operating conditions. If used in a wet area (pool, spa room, or basement prone to flooding), a ground fault interrupter protected circuit is recommended.

3.3 Condensate (Water) Removal

Condensate drains by gravity via the clear hose extending from the unit. Use care to keep the hose as flat to the floor as possible. Excessive humps or kinks will prevent proper drainage. If the Santa Fe HC is located too far from a floor drain for the attached hose to reach, 1/2" PVC pipe can be used to extend it. It is commonly available in 10' lengths from building supply, plumbing and hardware stores. It will slide tightly inside the end of the drain hose. Space and location requirements should be taken into account when incorporating a trap for the assembly as shown in Figure 6.

⚠ CAUTION! For proper drainage, the unit must be mounted so the drain outlet is at least 4" above the floor drain, and must be fully supported under the base.

3.4 Drainage and Trap

The Santa Fe HC requires a trap. Unit should be located in an area where the unit's condensate (water) may be easily routed to a suitable drain.

Thread the PVC barb fitting into the drain outlet on the front of the unit. Push the hose onto the barb fitting past two barbs minimum to ensure a good fit.



PVC barb fitting

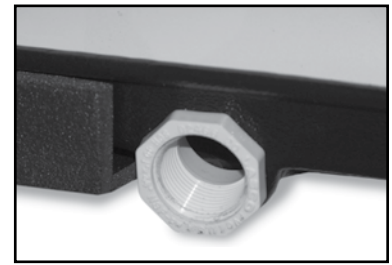

Drain outlet

Route the drain hose through the trap as shown below in Figure 6. Position the trap on the hose approximately 12" away from the unit.

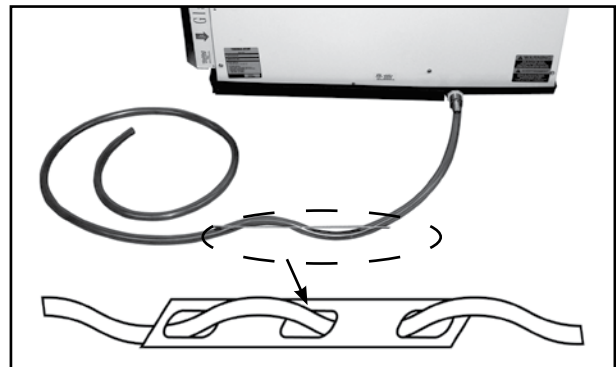

Figure 6: Trap diagram

4. Ducting

4.1 Optional Ducting Kit

10" collars may be attached to accept ducting on the inlet and/or outlet of the Santa Fe HC. The 10" outlet collar is included with the unit. Attaching a length of duct on the outlet collar will reduce the airflow noise significantly, and should be considered even if the duct is not required for other reasons.

A 10" inlet collar may be attached to duct inlet air. The inlet collar is a standard 10" starting collar available from the factory or local building supply stores.

4.2 Ducting for Dehumidification

Ducting the Santa Fe HC requires consideration of the following points:

Duct Sizing: For total duct lengths up to 50 feet, use a minimum 8" diameter round or equivalent rectangular. For longer lengths, use a minimum 10" diameter or equivalent. Grills or diffusers on the duct ends must not excessively restrict air flow

Isolated Areas: Effective dehumidification may require that ducting be branched to isolated, stagnant areas. Use 6" diameter branch ducting to each of two or three areas, use 4" to each of four or more areas.

5. Operation

5.1 Humidity Control Adjustment

The humidity control is an adjustable switch that closes when the relative humidity of the air in which it is located rises to the dial set point. It opens when the RH drops 4 to 6% below the set point.

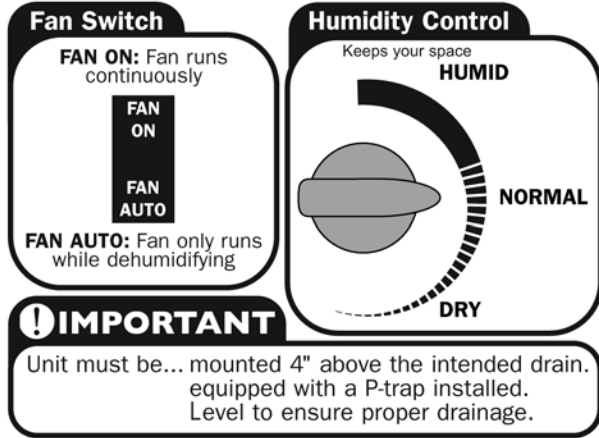

Approximate Humidity Levels Per Setting

“Dry”	35% to 45% Relative Humidity
“Normal”	45% to 55% Relative Humidity (Recommended)
“Humid”	55% to 65% Relative Humidity

The dehumidifier will run continuously until the relative humidity (RH) is reduced to the humidity control dial setting. The Santa Fe HC unit (and refrigerant based dehumidifiers in general) will reduce a warm space's RH to a lower level than that of a cool space. Therefore there is no benefit to set the humidity control to excessively low levels in cool rooms. Doing so will result in long periods of ineffective dehumidifier run time.

Quality humidity meters are available from the factory and are recommended to accurately monitor humidity levels. Refer to the options and accessories table in this document.

5.2 Blower (Fan) Switch

Turning the blower switch to “FAN ON” will cause the unit's internal blower to run continuously, whether the unit is dehumidifying or not. This function is desirable if the unit is used for air circulation.

Turning the blower switch to “FAN AUTO” will cause the unit's internal blower to run only while the unit is dehumidifying.

6. Maintenance

⚠ WARNING! NOTE: Do not operate the unit without the filter or with a less effective filter. The heat exchange coils inside the unit could become clogged and require disassembly to clean.

6.1 Air Filter

The Santa Fe HC ships with a standard MERV 11 65% efficient pleated fabric filter. This should be checked every six months. Operating the unit with a dirty filter will reduce dehumidifier capacity and efficiency and may cause the compressor to cycle on and off unnecessarily.

The pleated fabric filter can generally be vacuumed clean several times before needing replacement. Replacement filters can be ordered from the factory. To order a replacement filter, refer to the options and accessories table in this document.

6.2 Blower Oiling

The blower motor has been lubricated at the factory for many years of normal operation.

7. Service

⚠ WARNING! Servicing the Santa Fe HC with its high pressure refrigerant system and high voltage circuitry presents a health hazard which could result in death, serious bodily injury, and/or property damage. Only qualified service people should service this unit.

7.1 Technical Description

The Santa Fe HC uses a refrigeration system similar to an air conditioner's to remove heat and moisture from incoming air, and add heat to the air that is discharged. Hot, high pressure refrigerant gas is routed from the compressor to the condenser coil. The refrigerant is cooled and condensed by giving up its heat to the air that is about to be discharged from the unit. The refrigerant liquid then passes through a filter/drier and capillary tubing which cause the refrigerant pressure and temperature to drop. It next enters the evaporator coil where it absorbs heat from the incoming air and evaporates.

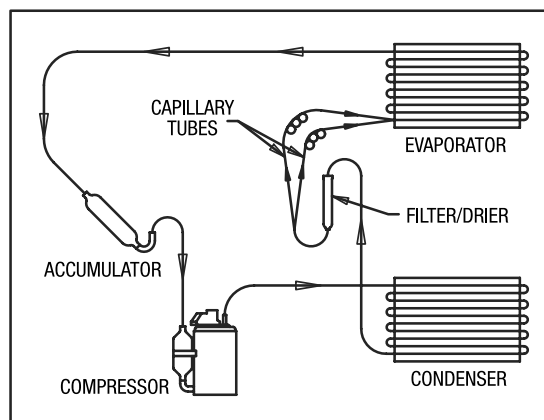

Santa Fe HC refrigeration system

The evaporator operates in a flooded condition, which means that all the evaporator tubes contain liquid refrigerant during normal operation. A flooded evaporator should maintain constant pressure and temperature across the entire coil, from inlet to outlet. The mixture of gas and liquid refrigerant enter the accumulator after leaving the evaporator coil. The accumulator prevents any liquid refrigerant from reaching the compressor. The compressor evacuates the cool refrigerant gas from the accumulator and compresses it to a high pressure and temperature gas to repeat the process.

7.2 Troubleshooting

No dehumidification, neither blower nor compressor run with fan switch OFF.

1. Unit unplugged or no power to outlet.
2. Humidity control set too high or defective.
3. Loose connection in internal wiring.

No dehumidification, compressor does not run but blower runs with fan switch OFF and humidity control turned to ON.

1. Defective compressor or compressor run capacitor.
2. Loose connection in compressor circuit.
3. Defective compressor overload.
4. Defrost thermostat open.

Blower runs with fan switch OFF, but compressor cycles on & off.

1. Low ambient temperature and/or humidity causing unit to cycle through defrost mode.
2. Defective compressor overload.
3. Defective compressor.
4. Defrost thermostat defective.

Blower does not run with fan switch in either position. Compressor runs briefly but cycles on & off.

1. Loose connection in blower circuit.
2. Obstruction prevents impeller rotation.
3. Defective blower.
4. Defective blower switch.

Evaporator coil frosted continuously, low dehumidifying capacity.

1. Defrost thermostat loose or defective.
2. Low refrigerant charge
3. Dirty air filter or air flow restricted.

7.3 Defrost Thermostat

The defrost thermostat is attached to the refrigerant suction tube between the accumulator and compressor. It will automatically shut the compressor off if the low side refrigerant temperature drops due to excessive frost formation on the evaporator coil. The blower will continue to run, causing air to flow through the evaporator coil and melt the ice. When the ice has melted, the evaporator temperature will rise and the thermostat will restart the compressor.

8. Service Parts List

PART NO.	DESCRIPTION
4021395	Coil, Evaporator
4021396	Coil, Condenser
4021470	Thermostat, Defrost Control
4021589	Tube, CU, CPLRY
4025087	Filter, Drier
4021469	Controller, Humidity, Face Mount
4026827	Compressor
4025076	Fan, Motorized Impeller
4025224	Capacitor, Impeller
4027108	Capacitor, Run
4026828	Overload, Compressor
4025560	Switch, Rocker, On-Offr

9. Accessory/Replacement Parts

PART NO.	DESCRIPTION
4021475	Filter, Air
4021626	Hose, Vinyl
4025264	Trap, Drain
4021495	Knob, Plastic, Black
4025249	Outlet Collar

Optional 10" Inlet Collar



Included 10" Outlet Collar

Duct Collar Kit

To order, contact your reseller or call 1-800-533-7533.

10. Wiring Diagram

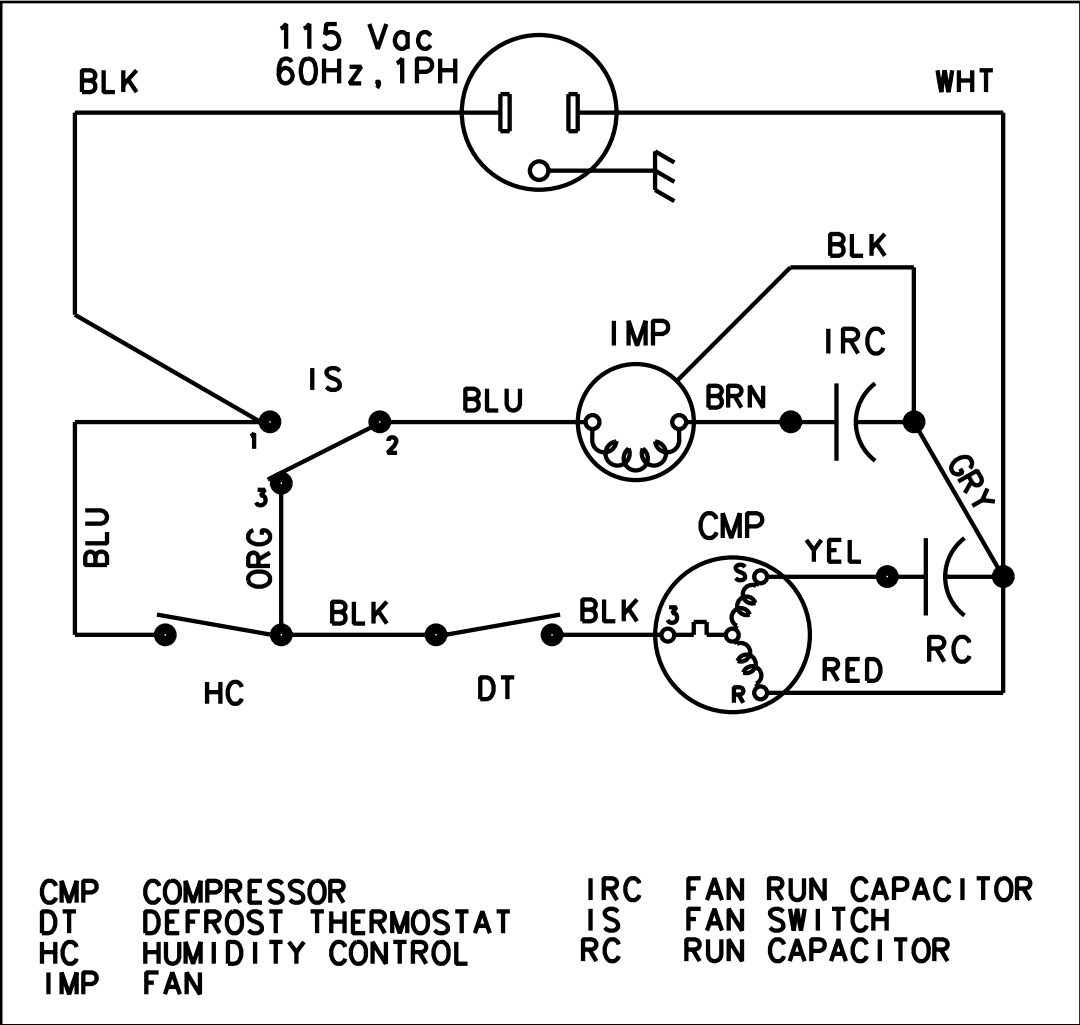

SANTA FE HC OPTIONAL REMOTE HUMIDITY CONTROL

Santa Fe HC Optional Remote Humidity Control

 **CAUTION! This should only be performed by a qualified electrician.**

A 120Vac remote humidity control is available from the factory. This replaces the factory mounted humidity control on the cabinet of the dehumidifier, and allows the unit to accurately sense the humidity in an area other than the one where the unit is located.

1. Unplug the unit.
2. Pull the black humidity control knob off from the back of the unit, exposing 2 screws. Remove the screws.
3. Remove the side panel of the dehumidifier by removing 9 hex screws. Remove four screws on back of unit to expose electbox.
4. Remove the 4 screws securing the wiring box to the inside of the blower end of the dehumidifier, and pull the box away from the cabinet to allow access.
5. Insert a romex connector or conduit connector into the hole in the cabinet that is left after the dehumidistat is removed. Pass the cable to be used to connect to the remote dehumidistat through the connector.
6. Disconnect the dehumidistat leads and reconnect with the new wires.
7. Replace the wiring box and screws. Replace the side cover and screws. Tighten any loose screws on the connector.
8. Run the new wire to the location desired to sense relative humidity. Install a 120 volt (ac) dehumidistat according to local electrical codes.

SANTA FE HC CONDENSATE PUMP INSTALLATION INSTRUCTIONS



STEP 1: The condensate pump kit includes: drain hose, condensate pump, two mounting screws and instructions.



STEP 2: Pre-drilled mounting holes are located near the bottom and on the same side of the unit as the drain hose.



STEP 3: Secure the condensate pump to the unit with the two provided screws.

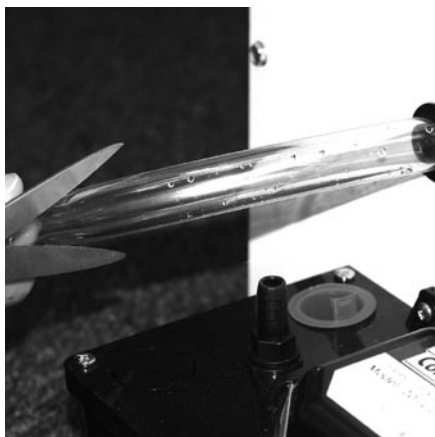

STEP 4: Cut the condensate drain hose at a 45° angle approximately 10 inches from the unit.

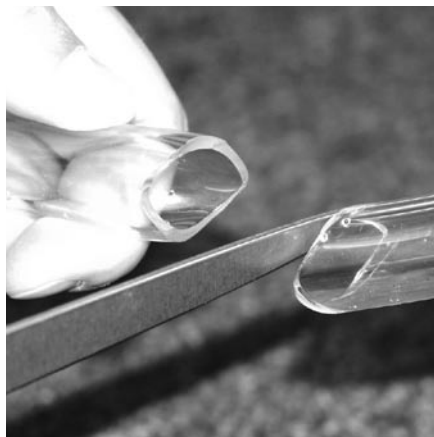

STEP 5: Example of hose cut at a 45° angle. The angle prevents the hose from sealing tight against the bottom of the pump reservoir.

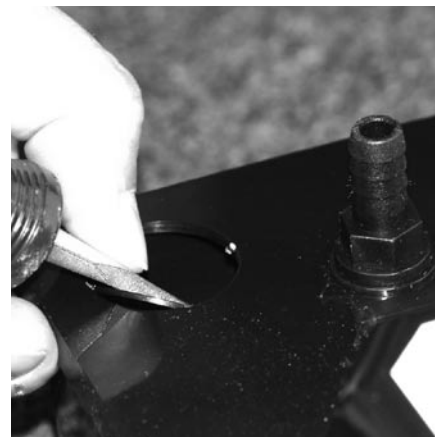

STEP 6: Remove the plug as shown.



STEP 7: Insert the drain hose into the condensate pump reservoir as shown.

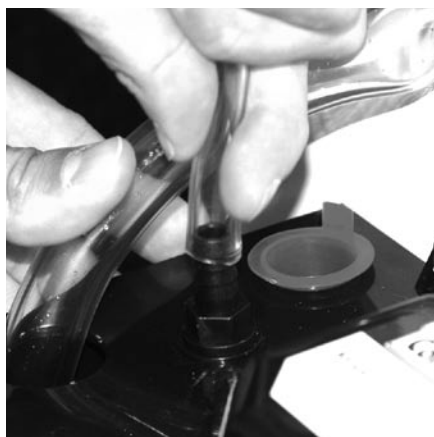

STEP 8: Install the provided drain hose over the condensate pump nipple.



STEP 9: Route the condensate pump drain hose to an appropriate drain and plug the condensate pump into a standard 115VAC outlet.



Santa FeTM Limited Warranty HC

Limited Warranty. Therma-Stor, LLC (“Therma-Stor”) warrants as follows: (i) the Santa Fe HC dehumidifier (“Product”) will be free of material defects in workmanship or materials for a period of one (1) year (“One-Year Warranty”) following the date of initial purchase of such Product by an original customer purchasing from Therma-Stor or an authorized reseller (“Customer”); and (ii) the Product’s condenser, evaporator, and compressor will be free of material defects in workmanship or materials for a period of five (5) years following the date of initial purchase of such Product by a Customer.

Limitation of Remedies. CUSTOMER’S SOLE AND EXCLUSIVE REMEDY UNDER THE ABOVE LIMITED WARRANTY AND THERMA-STOR’S ENTIRE LIABILITY THEREUNDER, SHALL BE, AT THE SOLE OPTION OF THERMA-STOR, REPLACEMENT OR REPAIR OF SUCH PRODUCT OR ITS COMPONENTS (“COMPONENTS”) BY THERMA-STOR OR THERMA-STOR’S AGENTS ONLY. REFRIGERANT, PIPING, SUPPLIES, TRANSPORTATION COSTS, LABOR COSTS INCURRED IN REPAIR OR REPLACEMENT OF SUCH COMPONENTS ARE NOT INCLUDED. THIS DISCLAIMER AND EXCLUSION SHALL APPLY EVEN IF THE EXPRESS WARRANTY AND LIMITED REMEDY SET FORTH HEREIN FAILS OF ITS ESSENTIAL PURPOSE. CUSTOMER ACKNOWLEDGES THAT NO REPRESENTATIVE OF THERMA-STOR OR OF ITS AFFILIATES OR RESELLERS IS AUTHORIZED TO MAKE ANY REPRESENTATION OR WARRANTY ON BEHALF OF THERMA-STOR OR ANY OF ITS AFFILIATES OR RESELLERS THAT IS NOT IN THIS AGREEMENT. Notwithstanding the above, during the term of the One-Year Warranty only, Therma-Stor will provide, free of charge to Customer, all Components and labor (except costs related to removal and installation of Product) required to fulfill its obligations under such One-Year Warranty.

Disclaimer of Warranties. EXCEPT FOR ABOVE LIMITED WARRANTY, WHICH IS THE SOLE AND EXCLUSIVE WARRANTY PROVIDED WITH RESPECT TO THE PRODUCT AND ITS COMPONENTS, THERMA-STOR HEREBY DISCLAIMS ALL EXPRESS AND IMPLIED WARRANTIES, INCLUDING, WITHOUT LIMITATION, THE IMPLIED WARRANTIES OF MERCHANTABILITY AND FITNESS FOR A PARTICULAR PURPOSE.

Warranty Limitations. The foregoing limited warranty extends only to a Customer and shall be null and void upon attempted assignment or transfer. A “defect” under the terms of the limited warranty shall not include problems resulting from Customer’s or Customer’s employees’, agents’, invitees’ or a third party’s misuse, improper installation, improper design of any system in which the Product is included, abuse, lack of normal care, failure to follow written instructions, tampering, improper repair, or freezing, corrosion, acts of nature or other causes not arising out of defects in Therma-Stor’s workmanship or material. If a Product or Component is replaced while under warranty, the applicable limited warranty period shall not be extended beyond the original warranty time period. The limited warranty does not cover any costs related to changes to a Product or Component that may be required by any codes, laws, or regulations that may become effective after initial purchase of the Product by Customer.

Customer Responsibilities. As a further condition to obtaining warranty coverage hereunder, the Customer must send a valid warranty claim to Therma-Stor such that Therma-Stor receives such claim prior to the end of the applicable warranty period. Therma-Stor shall have no obligation hereunder with respect to any claim received by Therma-Stor after the expiration of the applicable warranty period. As a further condition to obtaining warranty coverage hereunder, the Customer must present forms of invoices evidencing proof of purchase of a Product. If such invoices do not clearly indicate the date of initial purchase by a Customer, the applicable Product’s date of manufacture will be used instead of the date of initial purchase for the purpose of calculating the commencement of the applicable warranty period. Warranty service must be performed by Therma-Stor or a servicer authorized by Therma-Stor. In order to obtain warranty service, the Customer should call Therma-Stor at 1-800-533-7533 and ask for the Therma-Stor Products Service Department, which will then arrange for applicable warranty service. Warranty service will be performed during customary, daytime working hours. If the Product must be shipped for service, Customer shall be solely responsible for properly packaging the Product, for all freight charges, and for all risk of loss associated with shipment.

Limitation of Liability. IN NO EVENT SHALL THERMA-STOR, IN CONNECTION WITH THE DESIGN, SALE, INSTALLATION, USE, REPAIR, REPLACEMENT OR PERFORMANCE OF ANY PRODUCT, COMPONENT, PART THEREOF OR WRITTEN MATERIAL PROVIDED THEREWITH, BE LIABLE, TO THE EXTENT ALLOWED UNDER APPLICABLE LAW, UNDER ANY LEGAL THEORY FOR ANY SPECIAL, DIRECT, INDIRECT, COLLATERAL OR CONSEQUENTIAL DAMAGES OF ANY KIND. NOTWITHSTANDING THE ABOVE LIMITATIONS AND WARRANTIES, THE SOLE AND EXCLUSIVE LIABILITY OF THERMA-STOR, REGARDLESS OF THE NATURE OR THEORY OF THE CLAIM, SHALL UNDER NO CIRCUMSTANCES EXCEED THE PURCHASE PRICE OF THE PRODUCT, COMPONENT OR PART UPON WHICH THE CLAIM IS PREMISED.

Applicable Law and Venue. ANY ARBITRATION, ENFORCEMENT OF AN ARBITRATION OR LITIGATION RELATED TO THE PRODUCT WILL BE BROUGHT EXCLUSIVELY IN DANE COUNTY, WISCONSIN, AND CUSTOMER CONSENTS TO THE JURISDICTION OF THE FEDERAL AND STATE COURTS LOCATED THEREIN, SUBMITS TO THE JURISDICTION THEREOF AND WAIVES THE RIGHT TO CHANGE VENUE. CUSTOMER FURTHER CONSENTS TO THE EXERCISE OF PERSONAL JURISDICTION BY ANY SUCH COURT WITH RESPECT TO ANY SUCH PROCEEDING.

Miscellaneous. If any term or condition of this Limited Warranty is found by a court of competent jurisdiction to be invalid, illegal or otherwise unenforceable, the same shall not affect the other terms or conditions hereof or thereof or the whole of this Limited Warranty. Any delay or failure by Therma-Stor to exercise any right or remedy will not constitute a waiver of Therma-Stor to thereafter enforce such rights.



Therma-Stor LLC

PO Box 8680 • Madison, WI 53708

Phone: 608-222-5301 • Fax: 608-222-1447

Web: www.thermastor.com • Email: sales@thermastor.com

Information in this document is subject to change without notice. No part of this document may be reproduced or transmitted in any form or by any means, electronic or mechanical, for any purpose, without the express written permission of Therma-Stor LLC. © 2008 Therma-Stor LLC. All rights reserved.
