

# Panasonic<sup>®</sup> WhisperLite<sup>™</sup>

Advanced Ventilation Series



## CEILING MOUNT FAN/LIGHT COMBINATION

Quiet .5/1.0/1.5 Sone • Low Wattage • Long Life

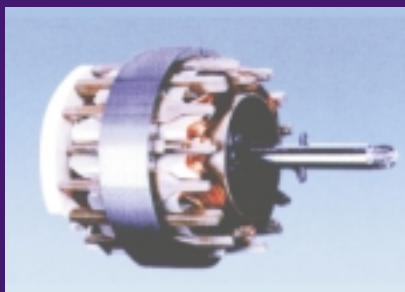

New Condenser Motor



FDS13  
2 Lamps Included

# Panasonic®

Quiet Low Wattage  
Fan/Light Series

**FV-07VQL**

**FV-08VQL**

**FV-11VQL**

The WhisperLite Series is a new generation of ventilating fan and light fixtures that provide ultra quiet ventilation and warm color corrected lighting in an energy efficient fan/light combination. Panasonic's two 13 watt compact fluorescent lamps output over 1700 lumens (equivalent to two 60 watt incandescent bulbs).

Many fans in today's market are noisy and ineffective because people refuse to use them or use them only for a short period of time. Yet today's homes and apartments are built more tightly and need more ventilation to maintain a healthy indoor environment. Panasonic WhisperLite offers a solution to ventilation problems.

### WhisperLite models feature:

**QUIET:** WhisperLite models have a sound rating of 0.5, 1.0 and 1.5 sones. Reducing noise leads to longer run times resulting in better indoor air quality and reduced building maintenance from moisture damage.

**ENERGY EFFICIENT:** WhisperLite models are designed for low power consumption adopting Panasonic fluorescent lamps. Total fan/light combination is only 41.4 - 46.4 watts.

**LONG LIFE:** WhisperLite models are designed with new condenser fan motors that feature permanently lubricated metal bearings. This fan combined with Panasonic fluorescent lamps offers long life, convenience and comfort.

Other features:

- Easy installation
- Rust proof galvanized steel body
- Built-in damper to prevent back draft
- Thermal fuse protection
- Contemporary lighting grille design
- UL listed for tub/shower enclosure when used with GFCI branch circuit wiring
- 2 Panasonic 13 watt energy efficient lamps included

<b>FAN</b> (Static pressure at 0.1 inch w.g.)			
Specification	FV-07VQL	FV-08VQL	FV-11VQL
Air Volume (CFM)*	70	90	110
Power Consumption (watts)	15.4	17.4	20.4
Noise (sones)*	0.5	1.0	1.5
Speed(RPM)	853	934	1018
Current (amps)	0.35	0.2	0.35
Power Rating	120/60Hz	120/60Hz	120/60Hz
Motor Type-Condenser Motor	Yes	Yes	Yes
Type of Motor Bearing	Metal	Metal	Metal
Thermal Fuse (2)	Yes	Yes	Yes
Type of Blade	Sirocco	Sirocco	Sirocco
Duct Diameter (inch)	4.0	4.0	4.0
Mounting Diameter (inch sq.)	9 1/8	9 1/8	9 1/8
Grille Size (inch sq.)	12 3/5	12 3/5	12 3/5
Combined Gross Weight LB (Kg)	14 (6.3)	14 (6.3)	14 (6.3)
UL Tub/Shower Enclosure	Approved	Approved	Approved
Washington State VIAQ Code	Approved	Approved	Approved

\* HVI certified data

<b>LIGHT</b>			
Lamp Watts (FDS13E27.U/2)	2x13 watts	2x13 watts	2x13 watts
CRI	84	84	84
Color Temperature (K)	2,700	2,700	2,700
Rated Avg. Life (hrs)	10,000	10,000	10,000

Combined Wattage	14.4	43.4	46.4
------------------	------	------	------

## PERFORMANCE DATA

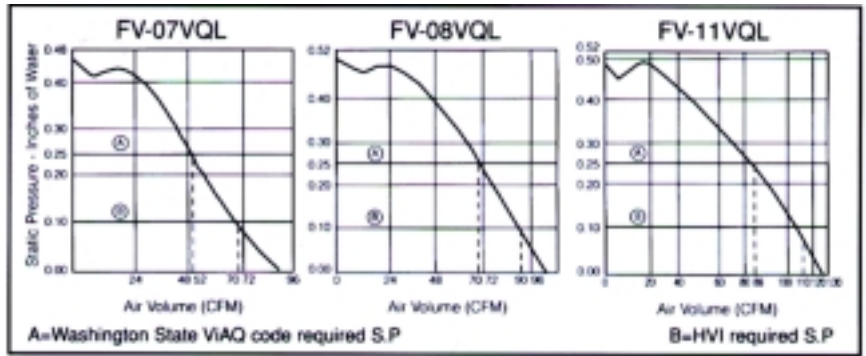

## DIMENSIONS

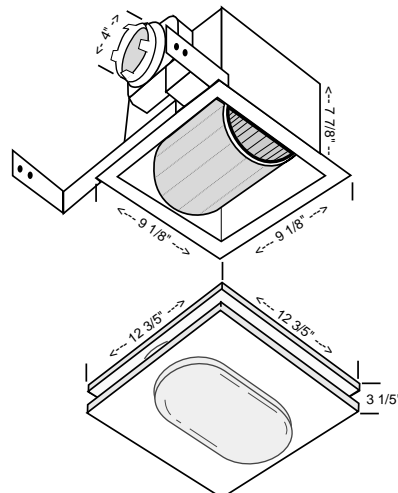

# Matsushita

Home and Commercial Products Company



Home and Building Products  
One Panasonic Way, 4A-4  
Secaucus, NJ 07094  
PHONE- 201-348-7231  
FAX-800-553-0384

