

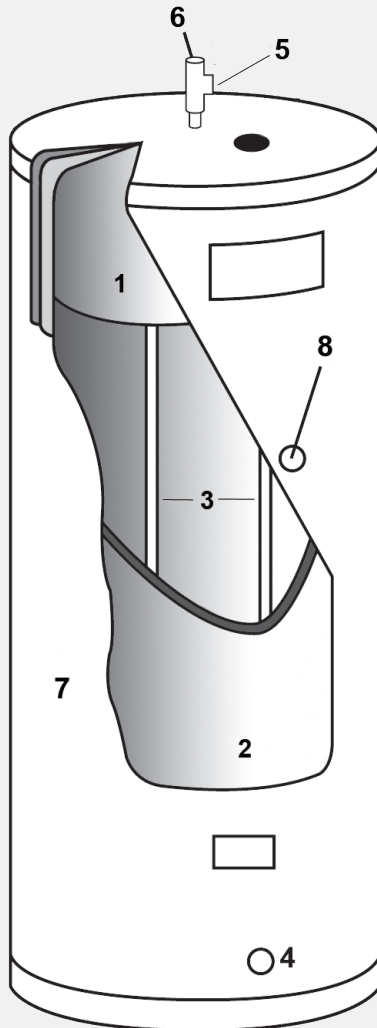

# Therma-Stor TS-120

## Storage Tank Specification Information



### Construction Specifications

1. Industrial glass lined 114-gallon hot water storage tank.
2. 2" foam-in-place urethane insulation (R-16).
3. Dual anode protection against corrosion for extended tank life.
4. 1-1/4" male NPT water inlet.
5. 1-1/4" male NPT water outlet.
6. 150 psi and 210°F pressure/temperature relief valve.
7. Attractive enameled galvanized external wrapper.
8. Mid tank 3/4" Male NPT connection for recirculating loop return or for aquastat (mid-port).

### Overview

The Therma-Stor TS-120 is an insulated 114-gallon water storage tank. Designed to complement Therma-Stor Heat Recovery Water Heating Systems, the TS-120 increases the capacity of heat reclaim systems by increasing hot water storage capacity.

### Operation

The Therma-Stor TS-120 stores hot water generated by Therma-Stor heat reclaim water heaters or other water heaters. Storing additional hot water allows the water heating system to buffer a larger quantity of hot water to meet periods of high demand. This is especially effective in facilities with larger refrigeration systems that use hot water in sporadic "batches" throughout the day.

### Typical Applications

The Therma-Stor TS-120 is ideally suited for facilities with high capacity refrigeration systems and "batched" hot water demand. The TS-120 is typically used in conjunction with Therma-Stor Heat Recovery Water Heaters. Common installations include:

- Grocery stores
- Supermarkets
- Processing facilities
- Ice rinks

### Unit Specifications

- Tank Dimensions  
Diameter: 28<sup>1</sup>/<sub>8</sub>", Height: 62<sup>1</sup>/<sub>4</sub>"
- Unit with Fittings Dimensions  
Diameter: 30<sup>3</sup>/<sub>8</sub>", Height: 67", Weight: 260 lbs
- 120 gallon nominal water capacity
- 150 psi maximum operating water pressure

Part No. 4016850

*Specifications subject to change without notice.*

### Certifications

- UL/cUL® (SA5939)
- ASHRAE 90
- CRN's available upon request

**Part No. 4016850 – TS-120**

In applications with “batch” water use (such as cleaning), adding a Therma-Stor TS-120 storage tank is recommended. The storage tank can be installed to accommodate thermal-syphoning (circulating without a pump). See diagram A below.

